

Introducing ElectroCraft's new MobilePower™ MPW52 wheel drive, featuring a high torque-density brushless DC motor with integrated single-stage planetary gearbox and wheel assembly.

ElectroCraft's MPW52 integrates a 14-pole Brushless DC motor with a heavy-duty, single-stage planetary gearbox mounted inside the hub of an aluminum wheel with polyurethane tread. Designed for mobile platform traction systems with optional encoder feedback to support positioning capability and electromagnetic brake to hold position when power is removed. The MPW52 combines optimum performance with high-efficiency, quiet operation and long life.

ElectroCraft MobilePower™ MPW series wheel drives feature an integrated design that provides increased performance and reliability at an affordable price compared to traditional motor/gearbox/wheel combinations. As with all ElectroCraft products, the MPW series wheel drives are customizable to meet specific application requirements.



Features:

- Smooth, efficient motion
- Compact, lightweight, durable and highly reliable integrated design
- Powerful starting torque:
 - Peak torque up to 12.4 Nm
 - Continuous torque up to 6.1 Nm
- Configurable or completely customizable designs
 - Motor, gearbox, wheel, brake, encoder, cabling
- Typical applications:
 - Automated Guided Vehicles
 - Autonomous Mobile Robots

M P W 5 2	6 0 0 V	2 4	0 0 0 0	S 009
Motor and Gearbox Type Mobile Power™ Wheel Drive 52 mm frame	Motor Stall Torque 300 mNm 600 mNm	Winding Voltage 24 VDC 48 VDC	Wheel X - None 0 - 150 mm	Mounting 0 - Face 1 - Foot
			Brake 0 - No Brake 1 - Brake	Leads 0 - Flying Leads
				Feedback X - Hall Sensors S - 2048 Differential, Commutating, Optical Encoder
				Gear Ratio 9.00:1

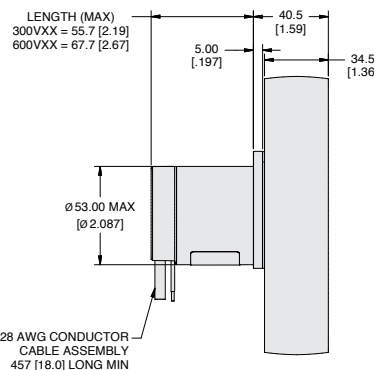
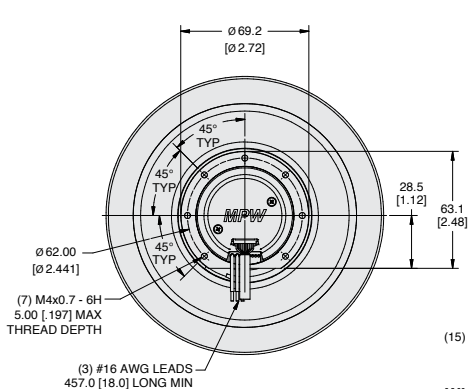

WHEEL OPTION 0; FEEDBACK OPTION S

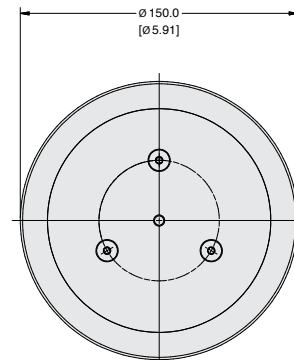

WHEEL MATERIAL: RED POLYETHER SHORE A 70

MPW52 Performance

MPW52-300

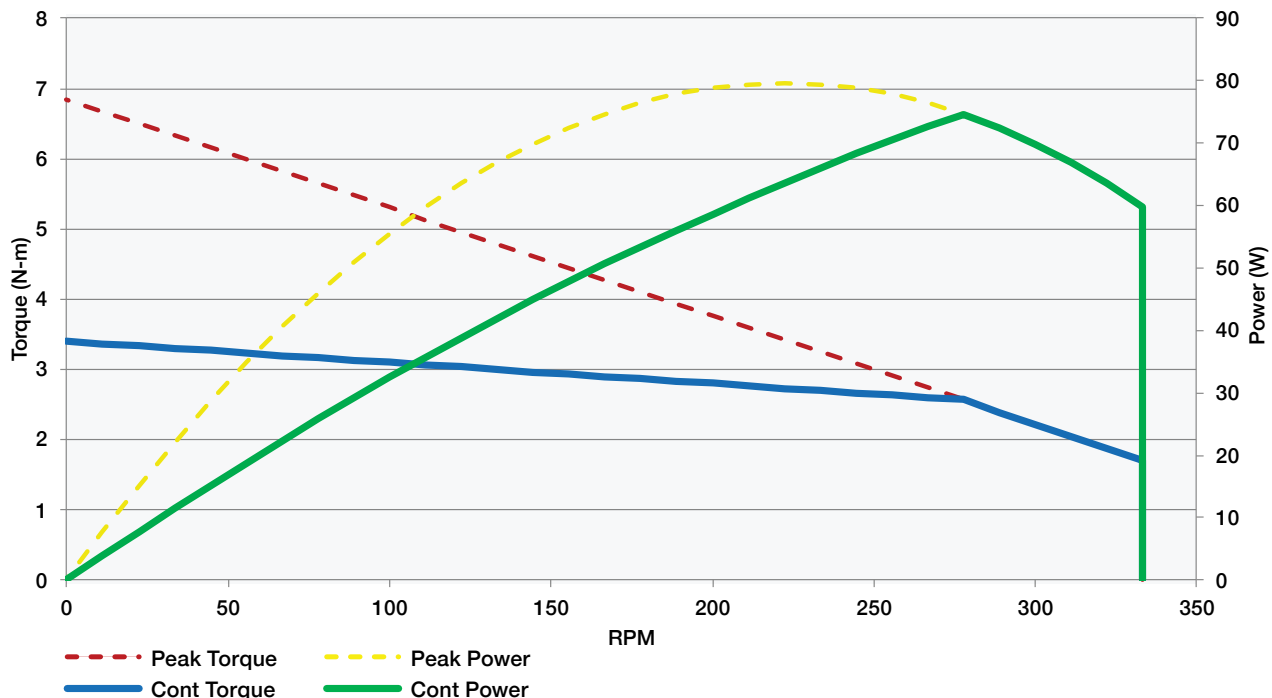

MPW52-600

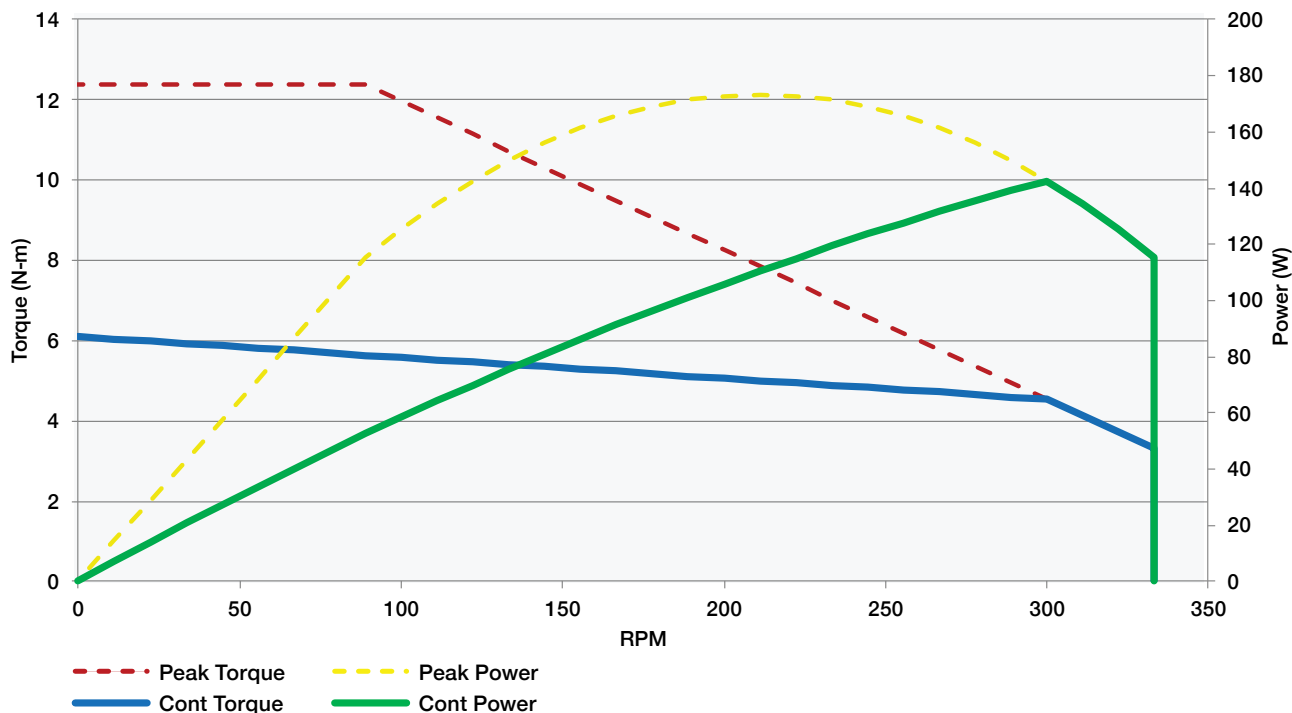

MPW52 Specifications

MPW52 Wheel Drive Specifications	Motor Stack Size & Winding Models			
	MPW52-300V24	MPW52-300V48	MPW52-600V24	MPW52-600V48
Design Voltage (VDC)	24	48	24	48
Gear Ratio	9.00:1			
Peak Torque (lb-in)	60.2		109.75	
Peak Torque (Nm)	6.8		12.4	
Peak Current (Amps)	17.4	8.6	26.5	12.9
Peak Power (Watts)	80		170	
Continuous Stall Torque* (lb-in)	30.1		54.0	
Continuous Stall Torque* (Nm)	3.4		6.1	
Continuous Stall Current (Amps)	6.4	3.4	11.4	5.6
Continuous Torque at Rated Speed* (lb-in)	23.0		39.8	
Continuous Torque at Rated Speed* (Nm)	2.6		4.5	
Continuous Current at Rated Speed (Amps)	5.0	2.5	8.4	4.2
Continuous Power at Rated Speed (Watts)	75		143	
Continuous Rated Wheel Speed (RPM)	278		300	
Continuous Rated Wheel Speed (Meters/Sec)	2.2		2.4	
Continuous Rated Wheel Speed (Feet/Sec)	7.2		7.7	
Continuous Rated Wheel Speed (KPH)	7.9		8.5	
Continuous Rated Wheel Speed (MPH)	4.9		5.3	
Standard Wheel Diameter (mm)	150			
Wheel Type / Hardness	Aluminum Hub with PTMEG POLYETHER Shore A 70 (Red)			
Maximum Axial Load (Kg)	22.7			
Maximum Axial Load (lbs)	50			
Maximum Radial Load (Kg)	68.0			
Maximum Radial Load (lbs)	150			
Peak Acceleration at Full Radial Load (m/s ²)	2.7		5.0	
Peak Efficiency (%)	75.0		80.0	
Backlash (degrees)	<1 deg			
Service Life (hours)	20,000			
Gear Motor Voltage Constant (V / kRPM)	98.4	196.9	103.6	207.2
Gear Motor Torque Constant (oz-in / Amp)	72.9	145.8	76.8	153.5
Gear Motor Torque Constant (Nm / Amp)	0.51	1.03	0.54	1.08
Motor Winding Resistance (Ohms)	0.74	2.66	0.28	1.16
Motor Winding Inductance (mH)	0.70	2.80	0.33	1.32
Motor Constant (oz-in / √ Watt)	9.4	9.9	16.1	16.1
Motor Constant (mNm / √ Watt)	66.3	70.2	113.6	113.6
Motor Electrical Constant (msec)	0.9	1.1	1.2	1.1
Motor Mechanical Constant (msec)	1.70		1.11	
Motor Thermal Time Constant (sec)	1,200.0		1,240.0	
Motor Rotor inertia (oz-in ²)	0.3390		0.5631	
Motor Rotor inertia (g-cm ²)	62.0		103.0	
Motor Thermal Resistance (C / Watt)	2.79		2.32	
Number of Motor Poles	14.0			
Total Weight - motor & gearbox only (lb)	2.8		3.1	
Total Weight - motor & gearbox only (Kg)	1.25		1.41	
Total Length - w/out encoder & brake (inch)	3.3		3.7	
Total Length - w/out encoder & brake (mm)	83		95	
Operating Temperature	-40 to 25C			
Storage Temperature	-40C to 60C			
Certifications	CE, RoHS			

Notes:

*Continuous rating based on a 25°C ambient temperature, winding temperature rise of 125°C. Mounted on a 150 X 150 X 6 mm aluminum heat sink.

